

# PROJECT PREMIUM

## MOULDED ACRYLIC INSET BATHS 1500 and 1675mm

SIZE	CODE:
1500 x 723 x 415	J5115A
1675 x 738 x 415	J5116A

### FEATURES

- Quality standard moulded inset bath
- Durable sanitary-grade acrylic material
- Comfortable shape with good lumbar support
- Slip-resistant bath floor, twin soap recesses
- Two sizes to suit most installations
- No mortar bed required in installation

### MODELS

Project Premium 1500 Bath 1500 x 723 x 415	J5115A
Project Premium 1675 Bath 1675 x 738 x 415	J5116A

### WARRANTY

Acrylic baths 15 years product replacement  
-refer to T&Cs at [www.johnsonsisuisse.com.au](http://www.johnsonsisuisse.com.au)



J5115A



J5116A



### PRODUCT DIMENSIONS

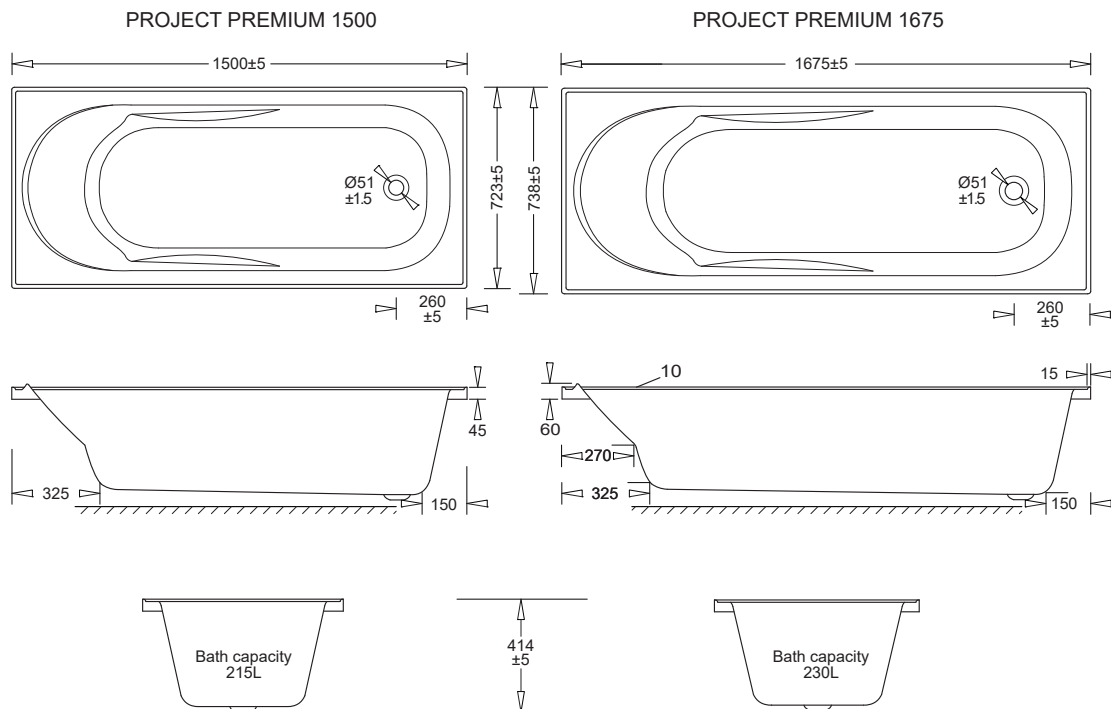

## TECHNICAL DATA SHEET

SUPERSEDES ALL PREVIOUS ISSUES

All dimensions are in millimetres and are subject to normal manufacturing variation.  
As product development is ongoing BPA reserves the right to vary specifications without notice.  
Bathroom Products Australia Pty Ltd ABN 87 079 297 617