

## ASSIST GRAB RAIL

SPECIAL NEEDS STAINLESS STEEL GRAB RAIL  
WITH CONCEALED WALL FLANGES



- Provides sturdy hand grip support around toilets, baths, showers or for general purpose assistance
- Compliant with AS1428.1 Design for Access and Mobility
- Quality construction in satin finished 304 stainless steel
- Suitable for installation in domestic or commercial installations
- 32mm diameter rail for comfortable grip
- Secure concealed flange fixing system

### DIMENSIONS

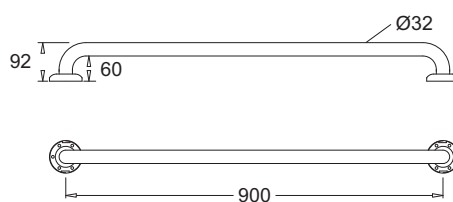

Compliant with AS1428.1 - Design for Access and Mobility

### TECHNICAL DATA SHEET

SUPERSEDES ALL PREVIOUS ISSUES

All dimensions are in millimetres and are subject to normal manufacturing variation.  
BPA reserves the right to vary specifications without notice.  
Bathroom Products Australia Pty. Ltd. ABN 87 079 297 617

0623

# FERLA/FELINO

## SHOWER PACK JTFN18

Triple Function Hand Shower

1.7m Hose

Wall Inlet with **Back-Flow Prevention Device**



XJTFN01



JTFN21



XJTFN03



# FERLA/FELINO

## TRIPLE FUNCTION HAND SHOWER SET WITH BACK-FLOW PREVENTION DEVICE



- Chrome finished ABS triple function hand shower
- Chrome plated, water inlet fitting (wall mounted) with Back-Flow prevention device
- 1.7m chrome finished shower hose
- Hand shower - attractive chrome face and silicone nozzles
- [WELS 3 Star, 8.5L/min. S14882](#)

### Contains

Item	Description	Code
Hand Shower	Ferla/Felino Triple Function Hand Shower	XJTFN01
Shower Hose	Chrome Finished Shower Hose - 1.7m	XJTFN03
Water Inlet	Chromed Brass Wall Mount Inlet + BF Prev.	JTFN21

### DIMENSIONS

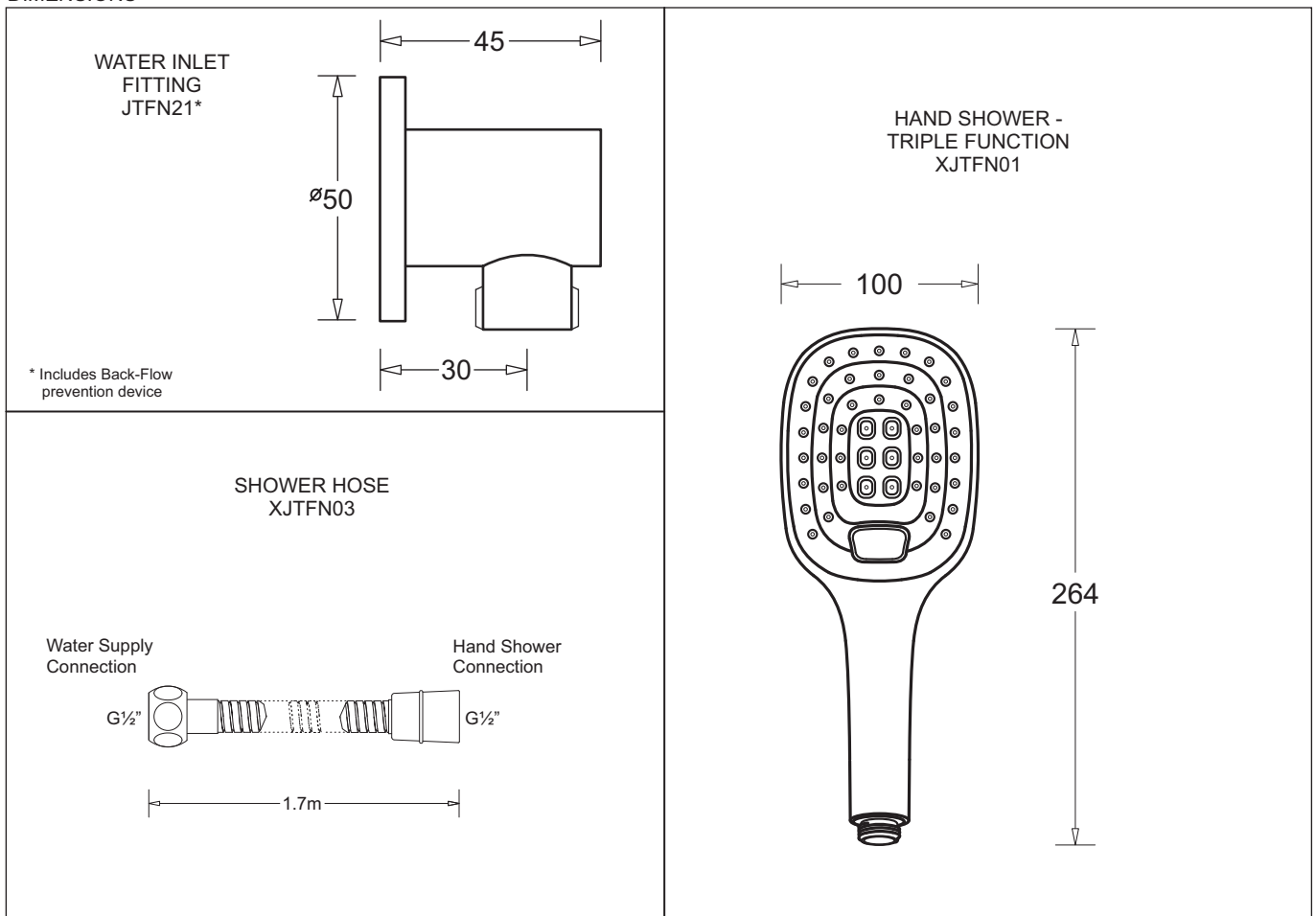

All dimensions are in millimetres and are subject to normal manufacturing variation.  
As product development is ongoing BPA reserves the right to vary specifications without notice.  
Bathroom Products Australia P/L ABN 87 079 297 617

# HAND SHOWER BRACKET FOR ASSIST GRABRAILS

CODE: CAC02

## FEATURES

- Bracket mounts to a 32mm vertical grabrail
- Reversible for left/right fitting
- Positive location and holding of the hand shower
- Slide/lock adjustability to accommodate different shower heights
- Click/lock settings to change spray shower angle
- Durable chrome finish
- Quick and easy installation



## MODEL

Hand shower bracket	Chrome	CAC02
---------------------	--------	-------

## WARRANTY

Accessories 10 years product replacement  
-refer to T&Cs at [www.johnsonsuiss.com.au](http://www.johnsonsuiss.com.au)



### Note:

This bracket is included as a component in a set with shower rail and hand shower\*:

- BR7011L.JTFN - LH shower rail + JTFN18 hand shower and hose
- BR7011R.JTFN- RH shower rail + JTFN18 hand shower and hose
- BR1090.JTFN- Vertical Shower rail + JTFN18 hand shower and hose

\* Wall elbow hose connection with check valve is also included

## DIMENSIONS

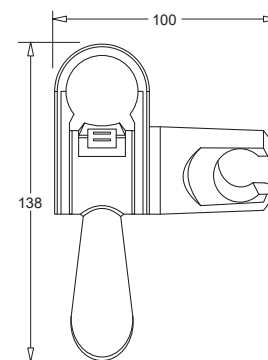

## COMPONENTS

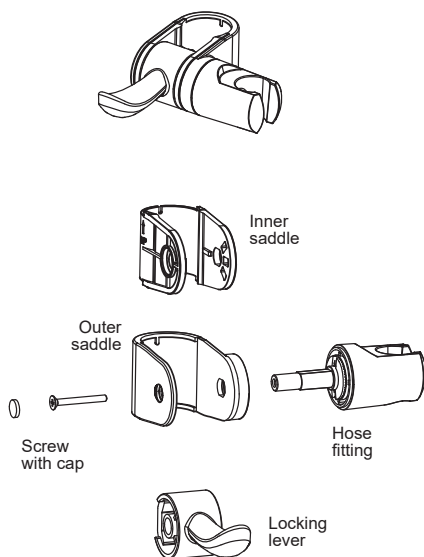

## ASSEMBLY

1. Disassemble the bracket to enable it to be placed over the grabrail.
2. Reassemble the shower bracket over the grabrail following the sequence 1,2,3,4.
3. When unlocked the shower bracket assembly can slide up or down the grabrail.
4. The locking lever should be in the 'middle' position for assembly

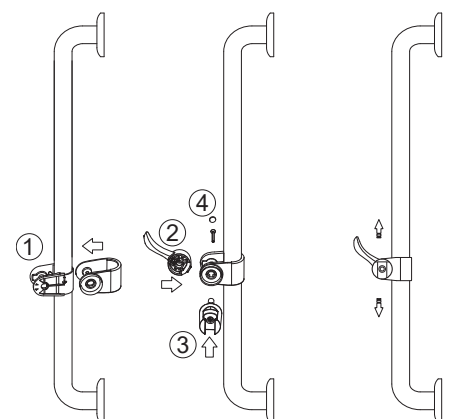

## TECHNICAL DATA SHEET

SUPERSEDES ALL PREVIOUS ISSUES

All dimensions are in millimetres and are subject to normal manufacturing variation.  
As product development is ongoing BPA reserves the right to vary specifications without notice.  
Bathroom Products Australia Pty Ltd ABN 87 079 297 617