

Venezia
Wall-Faced Bath

INSTALLATION GUIDE

JBTV3166

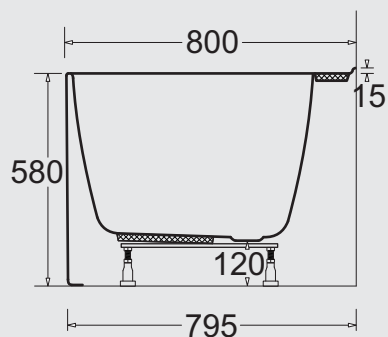
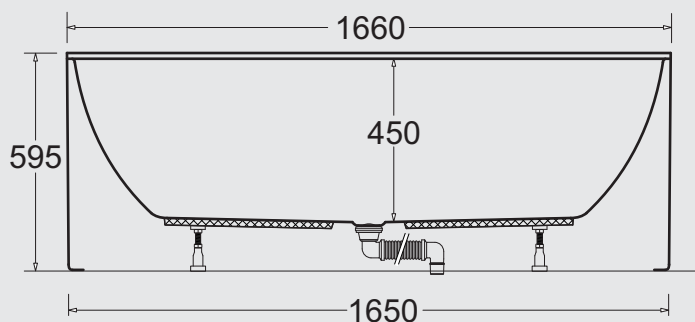
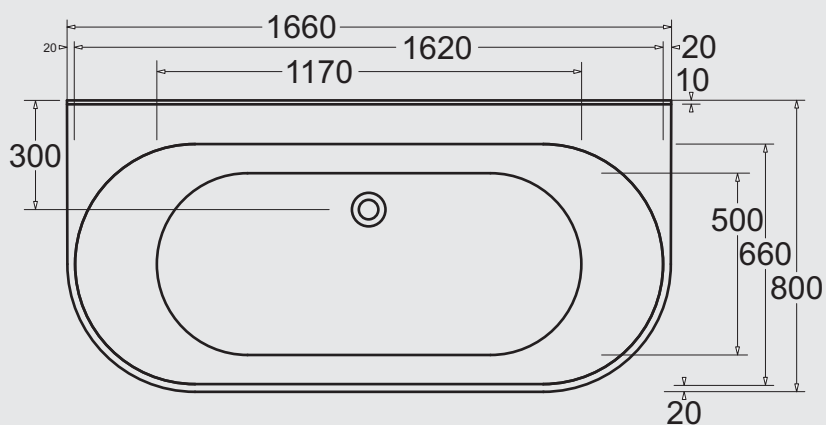
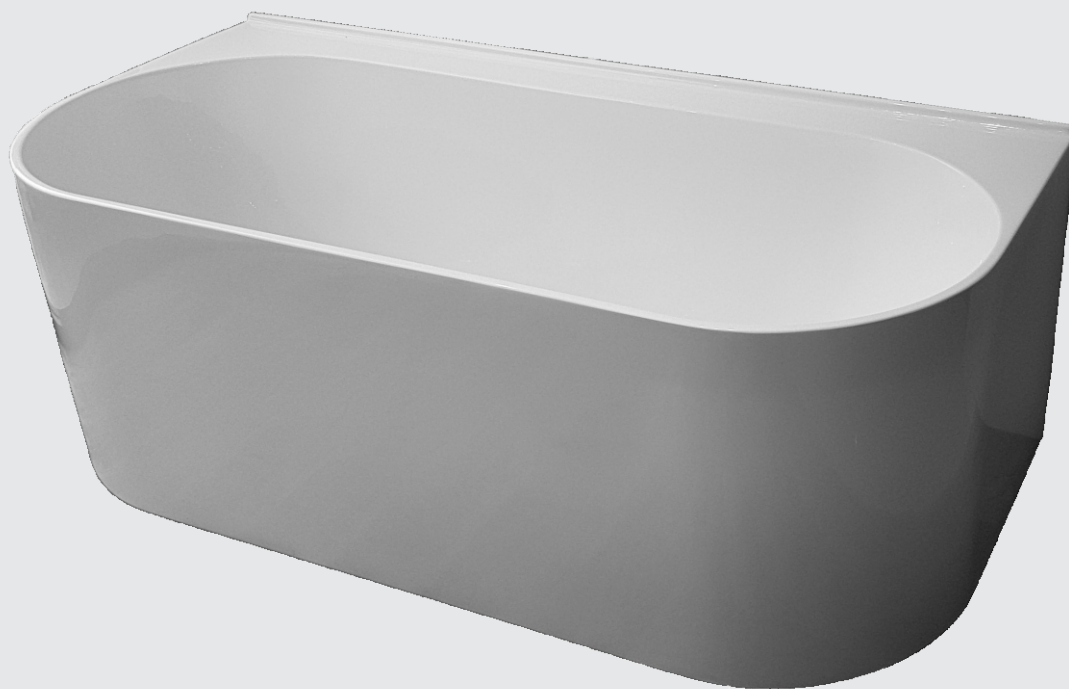

Venezia

Wall-Faced Bath

INSTALLATION GUIDE

INSTALLATION

Installation must be carried out by a licensed plumber in compliance with the Plumbing Code of Australia..

Check local and national building regulations before installation to ensure the below methods comply with the relevant codes.

Tools required for installation: Silicone Gun, Spirit Level, Tape Measure, Pencil, Adjustable Spanner.

1. Inspect bath thoroughly before installation. Claims for defects and/or damage must be made before installation commences.
2. Place bath in intended position against the wall and mark out position on the finished floor.
3. Check level by placing spirit level across the width and length of bath, then adjust feet to suit. Ensure the bath is fully supported on all feet.
4. Install feet-lockers for the back feet (two, close to wall - fig.3 and fig.5), push feet under, and connect waste to drainage using approved methods [Fig.1 and Fig.4].
5. Apply silicone or polyurethane to feet and bottom of bath skirt to secure to place.
6. Conduct final water test on bath to ensure water drains to waste.
7. Allow silicone 24 hours minimum curing time.
8. Install the Bath into the wall as per detail in Figure 2.

Note: Hot water applied to this product must not exceed 55°C.
Floor Trap is not included.

Figure 1

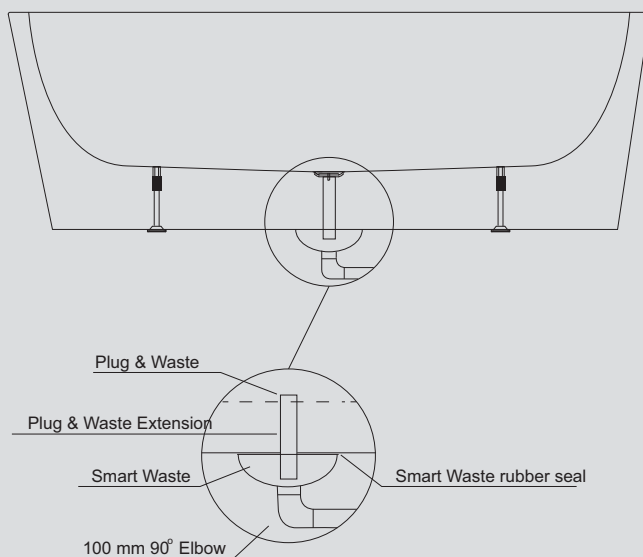

Figure 2

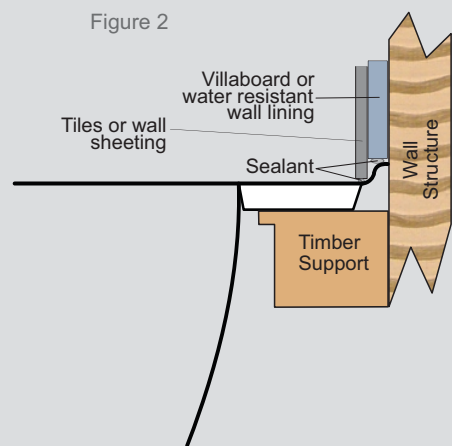
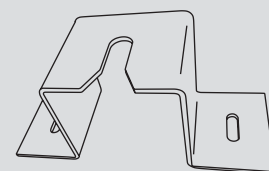

Figure 3



Venezia Wall-Faced Bath

INSTALLATION and CARE GUIDE

Figure 4

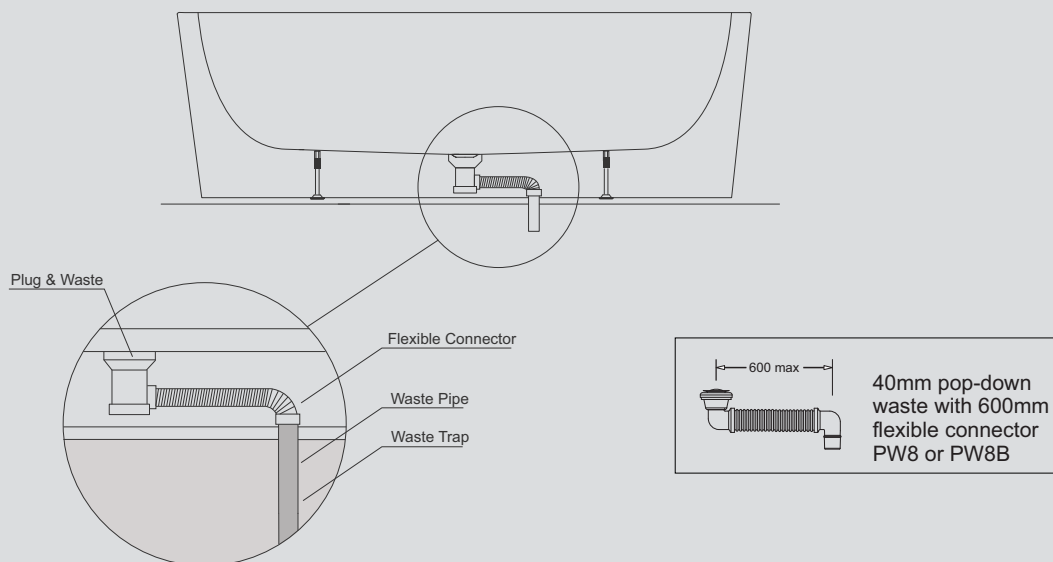
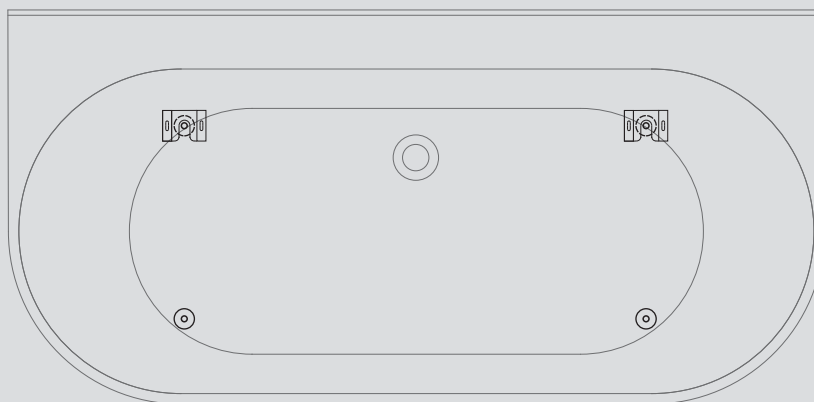

Figure 5



Your Venezia Wall-Faced Bath is manufactured using Lucite® sanitary grade acrylic. To maintain your bath's high gloss finish, please follow these simple instructions:

General Cleaning

Wipe acrylic with a mild soap or detergent and lukewarm water solution, using a clean microfiber cloth. Rinse well, wring out microfiber cloth and wipe again to remove moisture and streaking.

Deep Cleaning

Work into surface a thin, even coat of Ultra Gloss Bathroom Cleaner & Polish, using a soft cotton towel. Lightly buff off excess residue with a dry portion of your towel.

After polishing, wipe with a clean damp microfiber cloth to completely remove excess residue and remove any electrostatic charges which may attract dust particles.

Deep scratches can be removed with fine grit wet/dry sand paper and buffed to a shine using Ultra Gloss.

Caution

Window cleaning fluids, scouring compounds, harsh chemical cleaners, gritty cloths, leaded or ethyl gasoline or strong solvents such as alcohol, acetone, etc. must not be used.

Do not place hot objects such as hair straighteners and curlers directly onto the surface.

Venezia

Wall-Faced Bath

GENERAL INFORMATION

**FOR FURTHER INFORMATION PLEASE
CONTACT YOUR NEAREST MARBLETREND
OFFICE:**

HEAD OFFICE (SYDNEY)

2/97 Banksia St, Botany, NSW 2019
T 1300 717 717 F 1300 746 480

MELBOURNE

31 Koornang Rd, Scoresby, VIC 3179
T 1300 717 717 F 1800 225 315

BRISBANE

1/477 Newman Rd, Geebung, QLD 4034
T 1300 717 717 F 1300 746 480

PERTH

27 Harris Rd, Malaga, WA 6090
T 1300 717 717 F 1800 746 480

WARRANTY INFORMATION

This warranty is provided by:
Bathroom Products Australia Pty Ltd

(ABN 87 079 297 617)

2/97 Banksia St
Botany NSW 2019
P 1300 717 717
F 1300 746 480
E bpa.warranty@johnsonsuiss.com.au

ADELAIDE

Rep: Terry Hayes
T 0499 221 201 F 1800 225 315

HOBART

Rep: Bob Moore
T 0428 223 116 F 1800 225 315

DUBBO

Rogers Agencies
6 Richard Ryan Pl, Dubbo NSW 2830
T 02 6882 2733 F 02 6882 2169

www.johnsonsuiss.com.au

Visit www.johnsonsuiss.com.au to view full warranty terms.

Our goods come with guarantees that cannot be excluded under the Australian Consumer Law. You are entitled to a replacement or refund for the major failure and for compensation for any other reasonably foreseeable loss or damage. You are also entitled to have the goods repaired or replaced if the goods fail to be of acceptable quality and the failure does not amount to a major failure.

www.johnsonsuiss.com.au